

CO.SIME.

EQUIPMENT FOR ATEX





GAS	II2G Ex d IIC /Ex e II
DUST	II2D Ex tD A21

IP66
IP66

Zone 1 - Zone 21 - Zone 2 - Zone 22
❄️-20°C ÷ ☀️+40°C ❄️-50°C ÷ ☀️+80°C

Materiale : Acciaio zincato
 Materiale : Lega leggera (L), ottone (D), acciaio inox
 a richiesta AISI 304 (Y), AISI 316 (YS)
 Guarnizioni : EPDM
 Guarnizioni : Silicone
 a richiesta

Material : Galvanized steel
 Material : light alloy (L), brass (D), stainless steel
 on request inox AISI 304 (Y), AISI 316 (YS)
 Gaskets : EPDM
 Gaskets : Silicon
 on request



	Tappi Plugs			
	Poliammide Polyamide	Acciaio Zincato Galvanized steel	Ottone Brass	Acciaio inox Stainless steel
x1.5	Codice Code	Codice Code	Codice Code	Codice Code
M12	PLG M12P	-	PLG 12MD	PLG 12MY
M16	PLG M16P	-	PLG 16MD	PLG 16MY
M20	PLG M20P	PLG 1M	PLG 1MD	PLG 1MY
M25	PLG M25P	PLG 1M	PLG 2MD	PLG 2MY
M32	PLG M32P	PLG 1M	PLG 3MD	PLG 3MY
M40	PLG M40P	PLG 1M	PLG 4MD	PLG 4MY
M50	PLG M50P	PLG 1M	PLG 5MD	PLG 5MY
M63	PLG M63P	PLG 1M	PLG 6MD	PLG 6MY

	Dadi Nuts			Guarnizione Gasket
	Poliammide Polyamide	Ottone Brass	Acciaio inox Stainless s.	Gomma EPDM EPDM rubber
	Codice Code	Codice Code	Codice Code	Codice Code
DL M12P	DL 12MD	DL 12MY	G 12	
DL M16P	DL 16MD	DL 16MY	G 16	
DL M20P	DL 1MD	DL 1MY	G 1	
DL M25P	DL 2MD	DL 2MY	G 2	
DL M32P	DL 3MD	DL 3MY	G 3	
DL M40P	DL 4MD	DL 4MY	G 4	
DL M50P	DL 5MD	DL 5MY	G 5	
DL M63P.	DL 6MD	DL 6MY	G 6	

Ø Gk	Tappi Plugs		
	Acciaio Zincato Galvanized steel	Ottone Brass	Acciaio inox Stainless steel
¼	PLG 28	PLG 28D	-
	PLG 38	PLG 38D	-
½	PLG 1	PLG 1D	PLG 1Y
¾	PLG 2	PLG 2D	PLG 2Y
1	PLG 3	PLG 3D	PLG 3Y
1¼	PLG 4	PLG 4D	-
1½	PLG 5	PLG 5D	PLG 5Y
2	PLG 6	PLG 6D	PLG 6Y
2½	PLG 7	PLG 7D	-
3	PLG 8	PLG 8D	-

	Dadi Nuts			Guarnizione Gasket
	Acciaio Zn Galvan. steel	Ottone Brass	Acciaio inox Stainless	Gomma EPDM EPDM rubber
	Codice Code	Codice Code	Codice Code	Codice Code
DL 28	DL 28D	-	G 28	
DL 38	DL 38D	-	G 38	
DL 1	DL 1D	DL 1Y	G 1	
DL 2	DL 2D	DL 2Y	G 2	
DL 3	DL 3D	DL 3Y	G 3	
DL 4	DL 4D	-	G 4	
DL 5	DL 5D	DL 5Y	G 5	
DL 6	DL 6D	DL 6Y	G 6	
DL 7	DL 7D	-	G 7	
DL 8	DL 8D	-	G 8	

Ø NPT	Tappi Plugs		
	Acciaio Zincato Galvanized steel	Ottone Brass	Acciaio inox Stainless steel
½	PLG 1N	PLG 1ND	PLG 1NY
¾	PLG 2N	PLG 2ND	PLG 2NY
1	PLG 3N	PLG 3ND	PLG 3NY
1¼	PLG 4N	PLG 4ND	-
1½	PLG 5N	PLG 5ND	PLG 5NY
2	PLG 6N	PLG 6ND	PLG 6NY
2½	PLG 7N	PLG 7ND	-
3	PLG 8N	PLG 8ND	-

	Dadi Nuts			Guarnizione Gasket
	Acciaio Zn Galvan. steel	Ottone Brass	Acciaio inox Stainless	Gomma EPDM EPDM rubber
	Codice Code	Codice Code	Codice Code	Codice Code
DL 1N	DL 1ND	DL 1NY	G 1	
DL 2N	DL 2ND	DL 2NY	G 2	
DL 3N	DL 3ND	DL 3NY	G 3	
DL 4N	DL 4ND	-	G 4	
DL 5N	DL 5ND	DL 5NY	G 5	
DL 6N	DL 6ND	DL 6NY	G 6	
DL 7N	DL 7ND	-	G 7	
DL 8N	DL 8ND	-	G 8	

Filettatura conica : protezione IP 66
 utilizzare sigillante Loctite 577
 Taper thread : protection IP 66
 use compound Loctite 577





GAS	II2G Ex d IIB /Ex d IIC	IP66*	Zone 1 - Zone 21 - Zone 2 - Zone 22
DUST	II2D Ex tb IIIC	IP66	❄️-20°C ÷ ☀️+40°C ❄️-50°C ÷ ☀️+80°C

Materiale : Acciaio zincato
 Materiale : acciaio inox AISI 304 (Y)
 a richiesta
 Guarnizioni : EPDM* (a richiesta per protezione GAS)
 Guarnizioni : Silicone
 a richiesta
 Material : Galvanized steel
 Material : Stainless steel inox AISI 304 (Y)
 Gaskets : EPDM* (on request for GAS protection)
 Gaskets : Silicon
 on request



Codice Code (Gk) IIB	Codice Code (NPT) IIB	Codice Code (Gk) IIC	Codice Code (NPT) IIC	Ø	ØA	B IIB	B IIC	ØC	Peso IIB Weight [kg]	Peso IIC Weight [kg]
BMF 1	BMF 1N	BMF 1H	BMF 1NH	½	35	60	65	13.5	0,146	0,234
BMF 2	BMF 2N	BMF 2H	BMF 2NH	¾	42	60	65	19	0,200	0,248
BMF 3	BMF 3N	BMF 3H	BMF 3NH	1	52	76	76	24.5	0,352	0,428
BMF 4	BMF 4N	BMF 4H	BMF 4NH	1¼						
BMF 5	BMF 5N	BMF 5H	BMF 5NH	1½	70	82	82	38.5	0,726	0,875
BMF 6	BMF 6N	BMF 6H	BMF 6NH	2	84	85	85	48	0,994	1,100
BMF 7	BMF 7N	BMF 7H	BMF 7NH	2½						
BMF 8	BMF 8N	BMF 8H	BMF 8NH	3	132	98	98	73	2,300	-
BMF 9	BMF 9N	BMF 9H	BMF 9NH	4	140	110	110	102.5	2,600	-

Codice Code (Gk) IIB	Codice Code (NPT) IIB	Codice Code (Gk) IIC	Codice Code (NPT) IIC	Ø	ØA	B IIB	B IIC	ØC	Peso IIB Weight [kg]	Peso IIC Weight [kg]
BFF 1	BFF 1N	BFF 1H	BFF 1NH	½	35	49	49	13.5	0,126	0,170
BFF 2	BFF 2N	BFF 2H	BFF 2NH	¾	42	49	49	19	0,166	0,300
BFF 3	BFF 3N	BFF 3H	BFF 3NH	1	52	62	62	24.5	0,238	0,368
BFF 4	BFF 4N	BFF 4H	BFF 4NH	1¼						
BFF 5	BFF 5N	BFF 5H	BFF 5NH	1½	70	62	62	38.5	0,620	0,790
BFF 6	BFF 6N	BFF 6H	BFF 6NH	2	84	67	67	48	0,876	0,978
BFF 7	BFF 7N	BFF 7H	BFF 7NH	2½						
BFF 8	BFF 8N	BFF 8H	BFF 8NH	3	132	74	74	73	2,800	-
BFF 9	BFF 9N	BFF 9H	BFF 9NH	4	140	83	83	102.5	-	-

Codice Code (Gk) IIB	Codice Code (NPT) IIB	Codice Code (Gk) IIC	Codice Code (NPT) IIC	Ø	ØA	B IIB	B IIC	ØC	Peso IIB Weight [kg]	Peso IIC Weight [kg]
BMM 1	BMM 1N	BMM 1H	BMM 1NH	½	35	72	84	13.5	0,170	0,234
BMM 2	BMM 2N	BMM 2H	BMM 2NH	¾	42	72	84	19	0,236	0,268
BMM 3	BMM 3N	BMM 3H	BMM 3NH	1	52	121	121	24.5	0,460	0,522
BMM 4	BMM 4N	BMM 4H	BMM 4NH	1¼						
BMM 5	BMM 5N	BMM 5H	BMM 5NH	1½	70	127	127	38.5	0,884	0,912
BMM 6	BMM 6N	BMM 6H	BMM 6NH	2	84	130	130	48	1,150	1,270
BMM 7	BMM 7N	BMM 7H	BMM 7NH	2½						
BMM 8	BMM 8N	BMM 8H	BMM 8NH	3	132	163	163	73	3200	-
BMM 9	BMM 9N	BMM 9H	BMM 9NH	4	140	175	175	102.5	-	-

Filettatura conica : protezione IP 66
 utilizzare sigillante Loctite 577
 Taper thread : protection IP 66
 use compound Loctite 577



A2



GAS	II2G Ex d IIC /Ex e II
DUST	II2D Ex tb IIIC

IP66
IP66

Zone 1 - Zone 21 - Zone 2 - Zone 22
❄️-20°C ÷ ☀️+40°C ❄️-50°C ÷ ☀️+80°C

Materiale tubo : Acciaio inox AISI 304
 Materiale calza: Acciaio inox AISI 304

Materiale raccordo: Acciaio zincato

Materiale raccordo: Acciaio inox AISI 304 suffisso Y (FNN ..Y/..) a richiesta

Material of tube : Stainless steel AISI 304
 Material of braid : Stainless steel AISI 304

Material end fitting : Galvanized steel

Material end fitting : Stainless steel AISI 304 suffix Y (FNN .. Y/..) on request

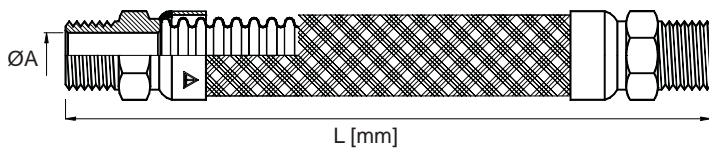

Codice Code (Gk)	Codice Code (NPT)	Ø	ØA
FNN 1/..	FNN 1N/..	½	14
FNN 2/..	FNN 2N/..	¾	19
FNN 3/..	FNN 3N/..	1	25
FNN 4/..	FNN 4N/..	1¼	
FNN 5/..	FNN 5N/..	1½	38
FNN 6/..	FNN 6N/..	2	48
FNN 7/..	FNN 7N/..	2½	65
FNN 8/..	FNN 8N/..	3	70
FNN 9/..	FNN 9N/..	4	192

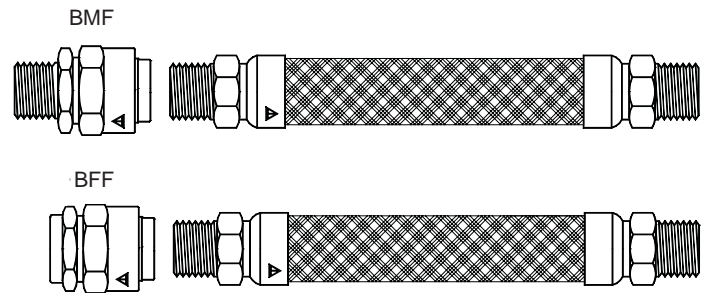

Codice Code (Gk)	L	Peso Weight [kg]
FNN 1/30	300±6	
FNN 1/42	425±6	
FNN 1/50	500±10	
FNN 1/60	600±10	
FNN 1/70	700±10	
FNN 1/80	800±10	
FNN 1/90	900±15	
FNN 1/100	1000±15	

Codice Code (Gk)	L	Peso Weight [kg]
FNN 2/30	300±6	
FNN 2/42	425±6	
FNN 2/50	500±10	
FNN 2/60	600±10	
FNN 2/70	700±10	
FNN 2/80	800±10	
FNN 2/90	900±15	
FNN 2/100	1000±15	

Codice Code (Gk)	L	Peso Weight [kg]
FNN 3/30	300±6	
FNN 3/40	425±6	
FNN 3/50	500±10	
FNN 3/60	600±10	
FNN 3/70	700±10	
FNN 3/80	800±10	
FNN 3/90	900±15	
FNN 3/100	1000±15	

Codice Code (Gk)	L	Peso Weight [kg]
FNN 5/40	400±10	
FNN 5/45	450±10	
FNN 5/50	500±10	
FNN 5/60	600±10	
FNN 5/70	700±10	
FNN 5/80	800±10	
FNN 5/90	900±15	
FNN 5/100	1000±15	

Codice Code (Gk)	L	Peso Weight [kg]
FNN 6/40	400±10	
FNN 6/45	450±10	
FNN 6/50	500±10	
FNN 6/60	600±10	
FNN 6/70	700±10	
FNN 6/80	800±10	
FNN 6/90	900±15	
FNN 6/100	1000±15	

Codice Code (Gk)	L	Peso Weight [kg]
-	-	-
-	-	-
FNN 7/50	500±10	
FNN 7/60	600±10	
FNN 6/70	700±10	
FNN 7/80	800±10	
FNN 7/90	900±15	
FNN 7/100	1000±15	

Codice Code (Gk)	L	Peso Weight [kg]
-	-	-
-	-	-
FNN 8/50	500±10	
FNN 8/60	600±10	
FNN 8/70	700±10	
FNN 8/80	800±10	
FNN 8/90	900±15	
FNN 8/100	1000±15	

Codice Code (Gk)	L	Peso Weight [kg]
-	-	-
-	-	-
-	-	-
-	-	-
FNN 9/70	700±10	
FNN 9/80	800±10	
FNN 9/90	900±15	
FNN 9/100	1000±15	

Altre lunghezze a richiesta max. 5000 mm
 Other lenght upon request max. 5000 mm

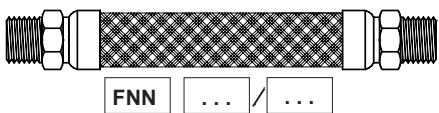

Filettatura conica : protezione IP 66
 utilizzare sigillante Loctite 577
 Taper thread : protection IP 66
 use compound Loctite 577

A3



GAS II2G Ex d IIB

Zone 1 - Zone 2

❄️-20°C ÷ ☀️+40°C

Materiale : Lega leggera
Viti : Acciaio zincato
Viti a richiesta : Acciaio inox

Material : Light alloy
Screws : Galvanized steel
Screws on request : Stainless steel



Codice Code (Gk)	Codice Code (NPT)	Ø	A	C	E	H	R	Peso Weight [kg]
LBH 1	LBH 1N	½	70	132	95	165	21	0,434
LBH 2	LBH 2N	¾	70	132	95	165	21	0,404
LBH 3	LBH 3N	1	70	132	112	168	30	0,455
LBH 4	LBH 4N	1¼	100	175	155	230	50	1,277
LBH 5	LBH 5N	1½	110	220	132	265	70	1,142
LBH 6	LBH 6N	2	110	220	132	265	70	1,024
LBH 7	LBH 7N	2½	136	267	250	363	96	3,569
LBH 8	LBH 8N	3	136	267	250	363	96	3,171
LBH 9	LBH 9N	4	181	605	305	720	125	10,850

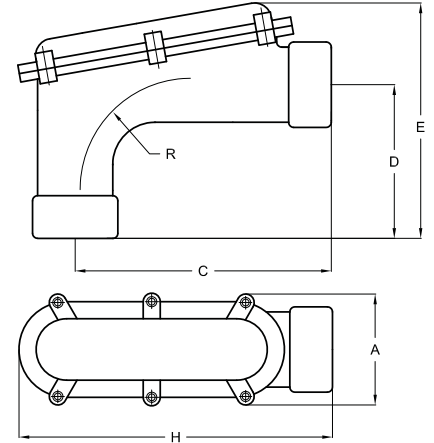

GAS II2G Ex d IIC /Ex e II

IP66

Zone 1 - Zone 21 - Zone 2 - Zone 22

DUST II2D Ex tD A21

IP66

❄️-20°C ÷ ☀️+40°C

❄️-50°C ÷ ☀️+80°C

Materiale : Lega leggera

Material : Light alloy

Codice Code (Gk)	Codice Code (NPT)	Ø	A	H	R	Peso Weight [kg]
ELF 1L	ELF 1LN	½	41	55	20	0,055
ELF 2L	ELF 2LN	¾	50	66	30	0,100
ELF 3L	ELF 3LN	1	66	88	35	0,200
ELF 4L	ELF 4LN	1¼	81	111	50	0,395
ELF 5L	ELF 5LN	1½	81	111	50	0,370
ELF 6L	ELF 6LN	2	94	131	60	0,625
ELF 7L	ELF 7LN	2½	110	155	65	0,880
ELF 8L	ELF 8LN	3	154	205	85	1,480
ELF 9L	ELF 9LN	4	163	220	100	2,345

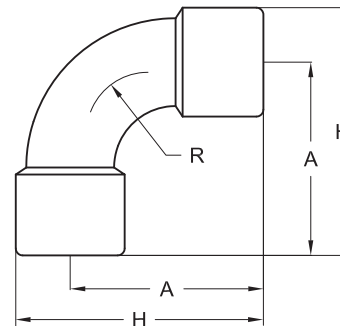

Filettatura conica : protezione IP 66
utilizzare sigillante Loctite 577
Taper thread : protection IP 66
use compound Loctite 577



GAS	II2G Ex d IIC /Ex e II
DUST	II2D Ex tD A21

IP66
IP66

Zone 1 - Zone 21 - Zone 2 - Zone 22
❄️-20°C ÷ ☀️+40°C ❄️-50°C ÷ ☀️+80°C

Materiale :	Acciaio zincato
Materiale : a richiesta	Acciaio inox AISI 304 (Y) Acciaio inox AISI 316 (YS)
Material :	Galvanized steel
Material : on request	Stainless steel inox AISI 304 (Y) Stainless steel inox AISI 316 (YS)

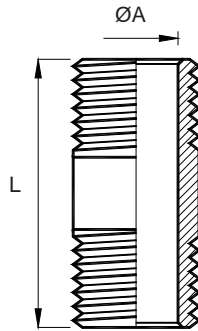

Codice Code (Gk)	Codice Code (NPT)	Ø	ØA	L
NP 1	NP 1N	½	14	70
NP 2	NP 2N	¾	19	70
NP 3	NP 3N	1	25	60
NP 4	NP 4N	1¼	31	55
NP 5	NP 5N	1½	38	55
NP 6	NP 6N	2	48	55
NP 7	NP 7N	2½	65	68
NP 8	NP 8N	3	70	68
NP 9	NP 9N	4	192	68

Filettatura conica : protezione IP 66
utilizzare sigillante Loctite 577
Taper thread : protection IP 66
use compound Loctite 577





GAS	II2G Ex d IIC /Ex e II
DUST	II2D Ex tD A21

IP66
IP66

Zone 1 - Zone 21 - Zone 2 - Zone 22
❄️-20°C ÷ ☀️+40°C ❄️-50°C ÷ ☀️+80°C

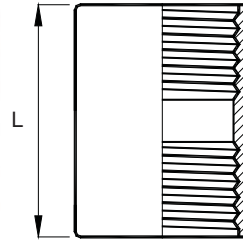
Materiale :	Acciaio zincato
Materiale : a richiesta	Acciaio inox AISI 304 (Y) Acciaio inox AISI 316 (YS)
Material :	Galvanized steel
Material : on request	Stainless steel inox AISI 304 (Y) Stainless steel inox AISI 316 (YS)



Codice Code (Gk)	Codice Code (NPT)	Ø	L
EMU 1	EMU 1N	½	39
EMU 2	EMU 2N	¾	51
EMU 3	EMU 3N	1	51
EMU 4	EMU 4N	1¼	51
EMU 5	EMU 5N	1½	51
EMU 6	EMU 6N	2	65
EMU 7	EMU 7N	2½	65
EMU 8	EMU 8N	3	65
EMU 9	EMU 9N	4	65

Filettatura conica : protezione IP 66
utilizzare sigillante Loctite 577
Taper thread : protection IP 66
use compound Loctite 577





GAS	II2G Ex d IIC /Ex e II
DUST	II2D Ex tb IIIC

IP66
IP66

Zone 1 - Zone 21 - Zone 2 - Zone 22
❄️-20°C ÷ ☀️+40°C ❄️-50°C ÷ ☀️+80°C

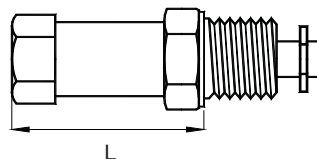
Materiale : a richiesta	Acciaio inox AISI 304 (Y) Acciaio inox AISI 316 (YS)
Guarnizione :	EPDM (a richiesta Silicone)
Material : on request	Stainless steel inox AISI 304 (Y) Stainless steel inox AISI 316 (YS)
Gasket:	EPDM (on request Silicon)



Codice Code	Ø	L
V 28	¼	31
V16	M16x1.5	31

Filettatura conica : protezione IP 66
utilizzare sigillante Loctite 577
Taper thread : protection IP 66
use compound Loctite 577





GAS	II2G Ex d IIB /Ex d IIC
DUST	II2D Ex tD A21

IP66
IP66

Zone 1 - Zone 21 - Zone 2 - Zone 22
❄️ -20°C ÷ ☀️ +40°C ❄️ -40°C ÷ ☀️ +80°C

Materiale :	Scatola Lega leggera, Tappo di acciaio zincato
Material :	Light alloy box Galvanized steel plug

Codice Code (Gk)	Codice Code (NPT)	Ø	A	B	MCK [gr]	Peso Weight [kg]
EYS 1	EYS 1N	½	80	47	25	0,118
EYS 2	EYS 2N	¾	90	56	50	0,180
EYS 3	EYS 3N	1	108	69	80	0,294

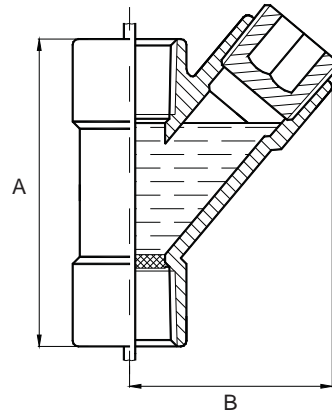

Codice Code (Gk)	Codice Code (NPT)	Ø	A	B	MCK [gr]	Peso Weight [kg]
EZS 1	EZS 1N	½	112	67	110	0,322
EZS 2	EZS 2N	¾	112	69	125	0,344
EZS 3	EZS 3N	1	118	75	180	0,342
EZS 4	EZS 4N	1¼				
EZS 5	EZS 5N	1½	118	83	300	0,424
EZS 6	EZS 6N	2	127	85	450	0,516
EZS 7	EZS 7N	2½				
EZS 8	EZS 8N	3	174	98	1100	1,276
EZS 9	EZS 9N	4	270	126	2800	2,500

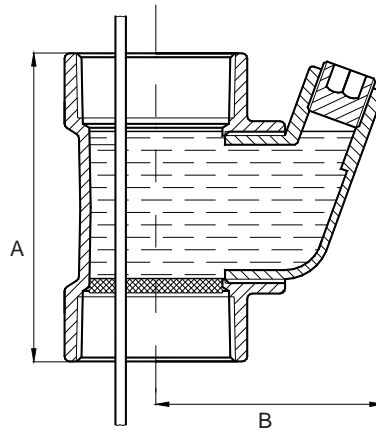

Codice Code	Peso netto resina + catalizzatore Net weight resin + hardner [gr]	Peso Weight [kg]
MCK 125	125	0,200
MCK 250	250	0,300
MCK 1000	1000	1,050

❄️ -40°C ÷ ☀️ +80°C

Caratteristiche miscela Compound features	
Rapporto di miscelazione in peso Mixing ratio	100 resina / 20 catalizzatore 100 resin / 20 hardner
Peso netto resina + catalizzatore Net weight resin + hardner	125-250-1000 [gr]
Temperatura consigliata di miscelazione Suggested mixing temperature	+10°C ±20°C
Potlife Gel time	15 min 35 ± 10 min
Indurimento completo Complete curing	36 h
Scadenza prodotto Process until	vedere data sulla confezione see date on the label



GAS
II2G Ex d IIC /Ex e II
IP66
Zone 1 - Zone 21 - Zone 2 - Zone 22
DUST
II2D Ex tD A21
IP66
❄️ -20°C ÷ ☀️ +40°C
❄️ -40°C ÷ ☀️ +80°C

Materiale : Acciaio zincato
 Materiale : Acciaio inox AISI 304 (Y)
 a richiesta Acciaio inox AISI 316 (YS)
 Lunghezza : 1 metro (altre lunghezze a richiesta)
 conduttori
 Material : *Galvanized steel*
 Material : *Stainless steel inox AISI 304 (Y)*
 on request *Stainless steel inox AISI 316 (YS)*
 Lenght : 1 meter (other lenght on request)
 conductors

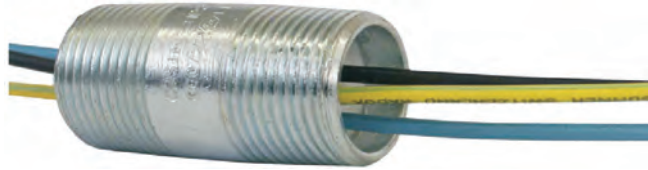
**Caratteristiche elettriche
Electrical features**

Sezione [mm ²] Cross section	Tensione nominale Rated voltage [V]	Corrente nominale per conduttore Rated current for each conductor @Tamb 40°C [A]	Corrente nominale per conduttore Rated current for each conductor @Tamb 55°C [A]	Corrente nominale per conduttore Rated current for each conductor @Tamb 80°C [A]
0,50	450/750	7,5	7	6
0,75	600/1000	10	9	7,5
1	600/1000	12	11	9,5
1,5	600/1000	15	13	11,5
2,5	600/1000	20	18,5	16
4	600/1000	26	23,5	20
6	600/1000	35	31	27
10	600/1000	50	46	40
16	600/1000	70	63	55
25	600/1000	90	80	70
35	600/1000	115	105	90
50	600/1000	140	130	110
70	600/1000	170	155	136

**Numero di conduttori per sezione del conduttore
Number of conductor for conductor section**

Codice Code (Gk)	Ø	0.5 ÷ 1.5 [mm ²]	2.5 [mm ²]	4 [mm ²]	6 [mm ²]	10 [mm ²]	16 [mm ²]	25 [mm ²]	35 [mm ²]	50 [mm ²]	70 [mm ²]
NP 1/RB	½	7	5	4							
NP 2/RB	¾	13	9	7	4	3					
NP 3/RB	1	21	15	11	7	4	3				
NP 4/RB	1¼	36	25	19	11	8	6	4			
NP 5/RB	1½	52	36	28	16	11	8	5	4	3	
NP 6/RB	2	85	59	45	26	18	13	9	7	5	4

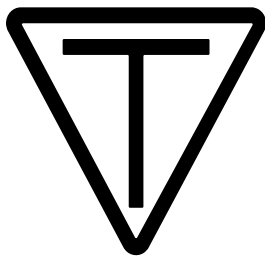

CO.SI.ME.
EQUIPMENT FOR ATEX





GAS	II2G Ex d IIC /Ex e II
DUST	II2D Ex tD A21

IP66
IP66

Zone 1 - Zone 21 - Zone 2 - Zone 22
❄️-20°C ÷ ☀️+40°C ❄️-50°C ÷ ☀️+80°C

Materiale : Acciaio zincato
 Materiale : Lega leggera (L), ottone (D), acciaio inox a richiesta
 Guarnizioni : Sigillante Loctite 577

Material : Galvanized steel
 Materiale : light alloy (L), brass (D), stainless steel on request
 Compound Loctite 577

RE	REB	REM
Riduzione ad anello maschio-femmina <i>Ring reducer male-female</i>	Riduzione a bicchiere femmina-maschio <i>Glass reducer female-male</i>	Riduzione ad bicchiere femmina-femmina <i>Glass reducer female-female</i>

Codice Code (Gk)	Codice Code (NPT)		Peso Weight [kg]
RE 21	RE 21N	3/4 1/2	
RE 31	RE 31N	3/4 1	
RE 32	RE 32N	1 3/4	
RE 41	RE 41N	1 1/4 1/2	
RE 42	RE 42N	1 1/4 3/4	
RE 43	RE 43N	1 1/4 1	
RE 51	RE 51N	1 1/2 1/2	
RE 52	RE 52N	1 1/2 3/4	
RE 53	RE 53N	1 1/2 1	
RE 54	RE 54N	1 1/2 1 1/4	
RE 61	RE 61N	2 1/2	
RE 62	RE 62N	2 3/4	
RE 63	RE 63N	2 1	
RE 64	RE 64N	2 1 1/4	
RE 65	RE 65N	2 1 1/2	
RE 71	RE 71N	2 1/2 1/2	
RE 72	RE 72N	2 1/2 3/4	
RE 73	RE 73N	2 1/2 1	
RE 74	RE 74N	2 1/2 1 1/4	
RE 75	RE 75N	2 1/2 1 1/2	
RE 76	RE 76N	2 1/2 2	
RE 81	RE 81N	3 1/2	
RE 82	RE 82N	3 3/4	
RE 83	RE 83N	3 1	
RE 84	RE 84N	3 1 1/4	
RE 85	RE 85N	3 1 1/2	
RE 86	RE 86N	3 2	
RE 87	RE 87N	3 2 1/2	
RE 98	RE 98N	4 3	

Codice Code (Gk)	Codice Code (NPT)		Peso Weight [kg]
REB 21	REB 21N	3/4 1/2	
REB 31	REB 31N	3/4 1	
REB 32	REB 32N	1 3/4	
REB 41	REB 41N	1 1/4 1/2	
REB 42	REB 42N	1 1/4 3/4	
REB 43	REB 43N	1 1/4 1	
REB 51	REB 51N	1 1/2 1/2	
REB 52	REB 52N	1 1/2 3/4	
REB 53	REB 53N	1 1/2 1	
REB 54	REB 54N	1 1/2 1 1/4	
REB 61	REB 61N	2 1/2	
REB 62	REB 62N	2 3/4	
REB 63	REB 63N	2 1	
REB 64	REB 64N	2 1 1/4	
REB 65	REB 65N	2 1 1/2	
REB 71	REB 71N	2 1/2 1/2	
REB 72	REB 72N	2 1/2 3/4	
REB 73	REB 73N	2 1/2 1	
REB 74	REB 74N	2 1/2 1 1/4	
REB 75	REB 75N	2 1/2 1 1/2	
REB 76	REB 76N	2 1/2 2	
REB 81	REB 81N	3 1/2	
REB 82	REB 82N	3 3/4	
REB 83	REB 83N	3 1	
REB 84	REB 84N	3 1 1/4	
REB 85	REB 85N	3 1 1/2	
REB 86	REB 86N	3 2	
REB 87	REB 87N	3 2 1/2	
REB 98	REB 98N	4 3	

Codice Code (Gk)	Codice Code (NPT)		Peso Weight [kg]
REM 21	REM 21N	1/2 1/2	
REM 31	REM 31N	3/4 1	
REM 32	REM 32N	1 3/4	
REM 41	REM 41N	1 1/4 1/2	
REM 42	REM 42N	1 1/4 3/4	
REM 43	REM 43N	1 1/4 1	
REM 51	REM 51N	1 1/2 1/2	
REM 52	REM 52N	1 1/2 3/4	
REM 53	REM 53N	1 1/2 1	
REM 54	REM 54N	1 1/2 1 1/4	
REM 61	REM 61N	2 1/2	
REM 62	REM 62N	2 3/4	
REM 63	REM 63N	2 1	
REM 64	REM 64N	2 1 1/4	
REM 65	REM 65N	2 1 1/2	
REM 71	REM 71N	2 1/2 1/2	
REM 72	REM 72N	2 1/2 3/4	
REM 73	REM 73N	2 1/2 1	
REM 74	REM 74N	2 1/2 1 1/4	
REM 75	REM 75N	2 1/2 1 1/2	
REM 76	REM 76N	2 1/2 2	
REM 81	REM 81N	3 1/2	
REM 82	REM 82N	3 3/4	
REM 83	REM 83N	3 1	
REM 84	REM 84N	3 1 1/4	
REM 85	REM 85N	3 1 1/2	
REM 86	REM 86N	3 2	
REM 87	REM 87N	3 2 1/2	
REM 98	REM 98N	4 3	



B1



GAS	II2G Ex d IIC /Ex e II	IP66	Zone 1 - Zone 21 - Zone 2 - Zone 22
DUST	II2D Ex tD A21	IP66	❄️-20°C ÷ ☀️+40°C ❄️-50°C ÷ ☀️+80°C

Materiale : Acciaio zincato
Materiale a richiesta : Lega leggera (L), ottone (D), acciaio inox AISI 304 (Y), AISI 316 (YS)
Guarnizioni : EPDM (filettatura cilindrica)
 Sigillante Loctite 577 (filettatura conica)
 Silicone (*cylindrical thread*)

Guarnizioni a richiesta :
Material : *Light alloy body*
Materiale on request : *light alloy (L), brass (D), stainless steel inox AISI 304 (Y), AISI 316 (YS)*

Gaskets : *EPDM (cylindrical thread)*
Compound Loctite 577 (taper thread)
Silicon (cylindrical thread)

Gaskets on request

RE	REB
Adattatore ad anello maschio-femmina <i>Ring adaptor male-female</i>	Adattatore a bicchiere femmina-maschio <i>Glass adaptor female-male</i>

			femmina-female NPT								
			1N	2N	3N	4N	5N	6N	7N	8N	9N
Code	Ø ext.	Gk	18,43	23,76	29,86	38,63	44,72	56,79	67,94	83,82	109,22
maschio-male Gk			½	¾	1	1¼	1½	2	2½	3	4
1	20,96	½									
2	28,44	¾									
3	33,25	1									
4	41,91	1¼									
5	47,80	1½									
6	59,61	2									
7	75,18	2½									
8	87,88	3									
9	113,03	4									

			femmina-female METRICAL PASSO / PITCH 1.5								
			16	20	25	32	40	50	63	75	90
Code	Ø ext.	Gk	14,50	18,50	23,50	30,50	38,50	48,50	61,50	73,50	88,50
maschio-male Gk			M16	M20	M25	M32	M40	M50	M63	M75	M90
1	20,96	½									
2	28,44	¾									
3	33,25	1									
4	41,91	1¼									
5	47,80	1½									
6	59,61	2									
7	75,18	2½									
8	87,88	3									
9	113,03	4									

			femmina - female Gk								
			1	2	3	4	5	6	7	8	9
Code	Ø ext.	Gk	18,63	24,12	30,29	38,95	44,85	56,66	72,23	84,93	110,07
maschio-male NPT			½	¾	1	1¼	1½	2	2½	3	4
1N	21,33	½									
2N	26,67	¾									
3N	33,40	1									
4N	42,17	1¼									
5N	48,26	1½									
6N	60,33	2									
7N	73,02	2½									
8N	88,90	3									
9N	114,30	4									

			femmina-female METRICAL PASSO / PITCH 1.5								
			16	20	25	32	40	50	63	75	90
Code	Ø ext.	Gk	14,50	18,50	23,50	30,50	38,50	48,50	61,50	73,50	88,50
maschio-male NPT			M16	M20	M25	M32	M40	M50	M63	M75	M90
1N	21,33	½									
2N	26,67	¾									
3N	33,40	1									
4N	42,17	1¼									
5N	48,26	1½									
6N	60,33	2									
7N	73,02	2½									
8N	88,90	3									
9N	114,30	4									

			femmina-female NPT								
			1N	2N	3N	4N	5N	6N	7N	8N	9N
Code	Ø ext.		18,43	23,76	29,86	38,63	44,72	56,79	67,94	83,82	109,22
maschio-male M			½	¾	1	1¼	1½	2	2½	3	4
16	21,33	M16									
20	26,67	M20									
25	33,40	M25									
32	42,17	M32									
40	48,26	M40									
50	60,33	M50									
63	73,02	M63									
75	88,90	M75									
90	114,30	M90									

			femmina - female Gk								
			1	2	3	4	5	6	7	8	9
Code	Ø ext.		18,63	24,12	30,29	38,95	44,85	56,66	72,23	84,93	110,07
maschio-male M			½	¾	1	1¼	1½	2	2½	3	4
16	21,33	M16									
20	26,67	M20									
25	33,40	M25									
32	42,17	M32									
40	48,26	M40									
50	60,33	M50									
63	73,02	M63									
75	88,90	M75									
90	114,30	M90									

Filettatura cilindrica
Cylindrical thread

Protezione IP 66 utilizzare guarnizione codice G ..
Protection IP 66 use gasket code G ..

Filettatura conica
Taper thread

Protezione IP 66 utilizzare sigillante Loctite 577
Protection IP 66 use compound Loctite 577

Esempio codice
Sample code

REB
female 2" NPT male M32x1.5
REB 6N.32

B2

GAS
II2G Ex d IIC /Ex e II
DUST
II2D Ex tD A21
IP66
Zone 1 - Zone 21 - Zone 2 - Zone 22
IP66
❄️-20°C ÷ ☀️+40°C
❄️-50°C ÷ ☀️+80°C

Materiale : Acciaio zincato
 Materiale : Lega leggera (L), ottone (D), acciaio inox
 a richiesta AISI 304 (Y), AISI 316 (YS)
 Guarnizioni : EPDM

Guarnizioni : Silicone
 a richiesta

Material : Galvanized steel
 Materiale : light alloy (L), brass (D), stainless steel
 on request inox AISI 304 (Y), AISI 316 (YS)

Gaskets : EPDM

Gaskets : Silicon
 on request



Codice Code)			Peso Weight [kg]
	M25	M20	
RE 25.20	M25	M20	
RE 32.20	M32	M20	
RE 32.25	M32	M25	
RE 40.20	M40	M20	
RE 40.25	M40	M25	
RE 40.32	M40	M32	
RE 50.20	M50	M20	
RE 50.25	M50	M25	
RE 50.32	M50	M32	
RE 50.40	M50	M40	
RE 63.20	M63	M20	
RE 63.25	M63	M25	
RE 63.32	M63	M32	
RE 63.40	M63	M40	
RE 63.50	M63	M50	
RE 75.20	M75	M20	
RE 75.25	M75	M25	
RE 75.32	M75	M32	
RE 75.40	M75	M40	
RE 75.50	M75	M50	
RE 75.63	M75	M63	
RE 90.20	M90	M20	
RE 90.25	M90	M25	
RE 90.32	M90	M32	
RE 90.40	M90	M40	
RE 90.50	M90	M50	
RE 90.63	M90	M63	
RE 90.75	M90	M75	

Codice Code)			Peso Weight [kg]
	M25	M20	
REB 25.20	M25	M20	
REB 32.20	M32	M20	
REB 32.25	M32	M25	
REB 40.20	M40	M20	
REB 40.25	M40	M25	
REB 40.32	M40	M32	
REB 50.20	M50	M20	
REB 50.25	M50	M25	
REB 50.32	M50	M32	
REB 50.40	M50	M40	
REB 63.20	M63	M20	
REB 63.25	M63	M25	
REB 63.32	M63	M32	
REB 63.40	M63	M40	
REB 63.50	M63	M50	
REB 75.20	M75	M20	
REB 75.25	M75	M25	
REB 75.32	M75	M32	
REB 75.40	M75	M40	
REB 75.50	M75	M50	
REB 75.63	M75	M63	
REB 90.20	M90	M20	
REB 90.25	M90	M25	
REB 90.32	M90	M32	
REB 90.40	M90	M40	
REB 90.50	M90	M50	
REB 90.63	M90	M63	
REB 90.75	M90	M75	

